

Tenor Sax Sheet Music with Lettered Noteheads: A Comprehensive Guide for Beginners

Welcome to the enchanting world of tenor sax sheet music with lettered noteheads! Embark on a captivating musical journey as we delve into the intricacies of this fascinating instrument and decipher the secrets of reading its sheet music seamlessly.

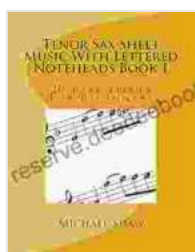

Tenor Sax Sheet Music With Lettered Noteheads Book 1: 20 Easy Pieces For Beginners by Michael Shaw

★★★★☆ 4 out of 5

Language	: English
File size	: 8804 KB
Text-to-Speech	: Enabled
Screen Reader	: Supported
Enhanced typesetting	: Enabled
Word Wise	: Enabled
Print length	: 72 pages
Lending	: Enabled



Whether you're a budding saxophonist or a seasoned musician seeking to expand your repertoire, this comprehensive guide will illuminate the path for you. With clear explanations, detailed diagrams, and a wealth of practice exercises, you'll master the art of interpreting tenor sax sheet music with lettered noteheads in no time.

Understanding Lettered Noteheads

At the heart of tenor sax sheet music lies the unique system of lettered noteheads. These noteheads are adorned with letters from A to G, representing the different notes in the musical scale. This ingenious notation simplifies the process of identifying notes, making it accessible to beginners and experienced players alike.

Here's a handy table to help you familiarize yourself with the lettered noteheads:

Note

Lettered Notehead

A

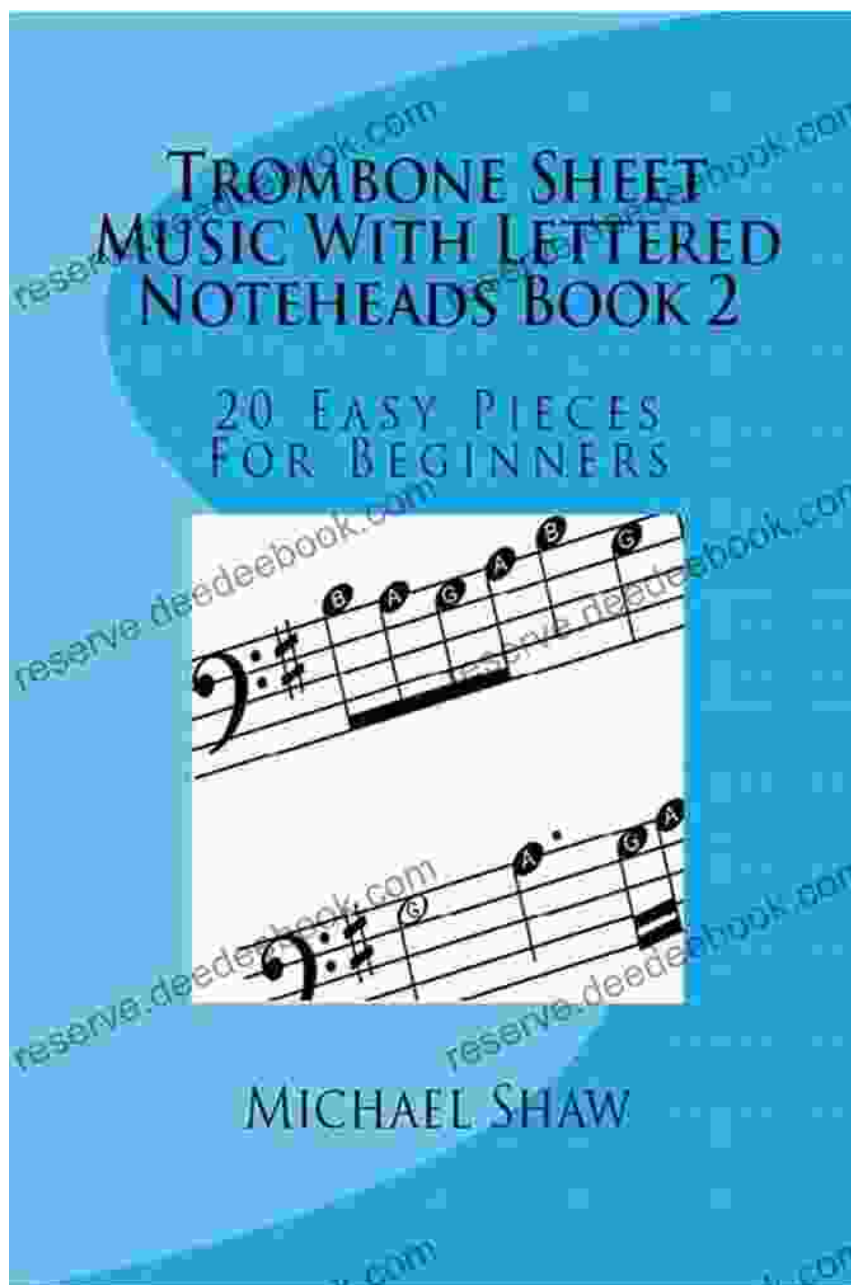

Note

Lettered Notehead

B

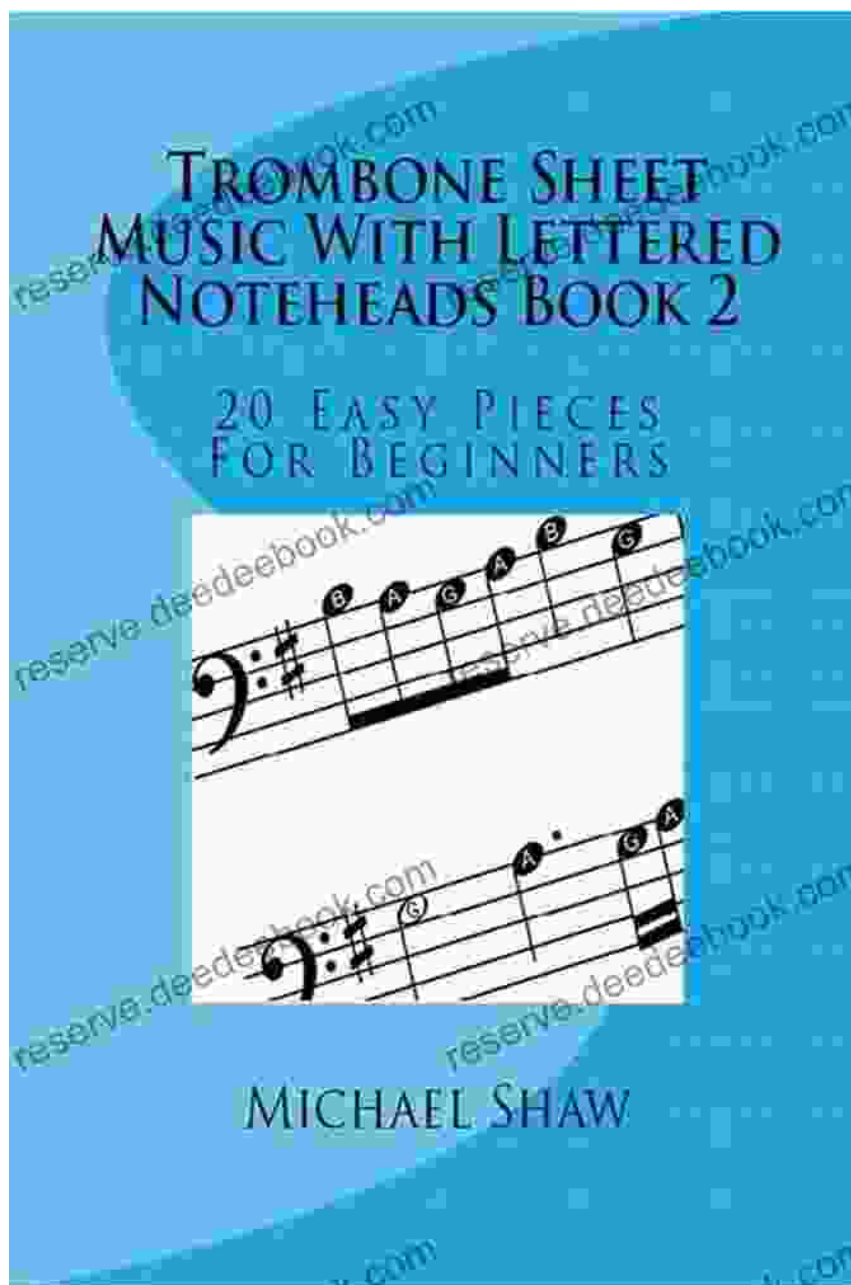

Note

Lettered Notehead

C

E♭ ALTO SAXOPHONE TRILL FINGERING CHART

Move the red key rapidly to produce the trill.
○ = open
● = pressed down

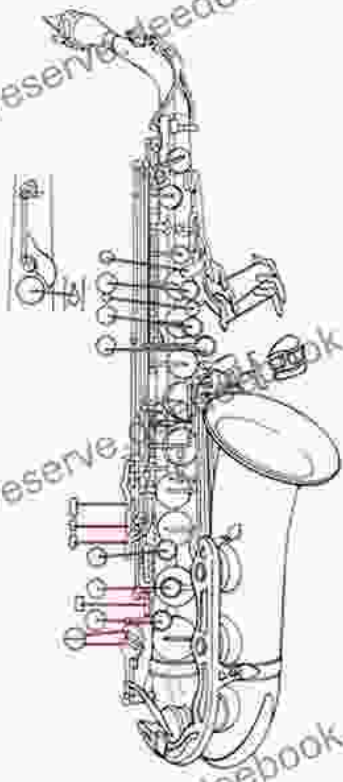

C♭ to D	D to E	E to F	F to G♭	F to G
G to A	A to B♭	A to B	A♭ to B	B to C
B to C	C to D	C to D	C to D	D to E
E♭ to F	F to G	F to G	A to B	A to B

B to C	B to C	C to D	C to D	C to D	D to E	E to F	E to F
--------	--------	--------	--------	--------	--------	--------	--------

Note Lettered Notehead

D

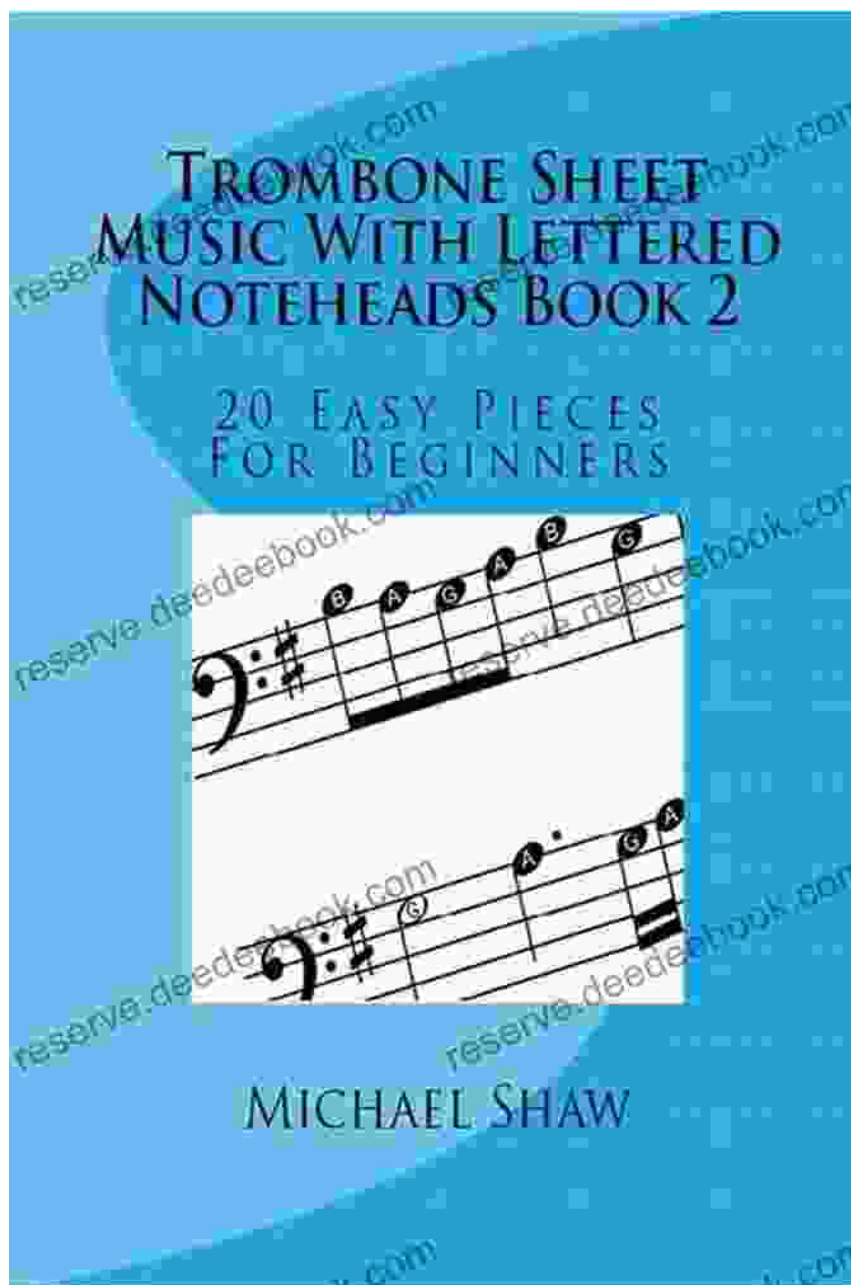

Note

Lettered Notehead

E

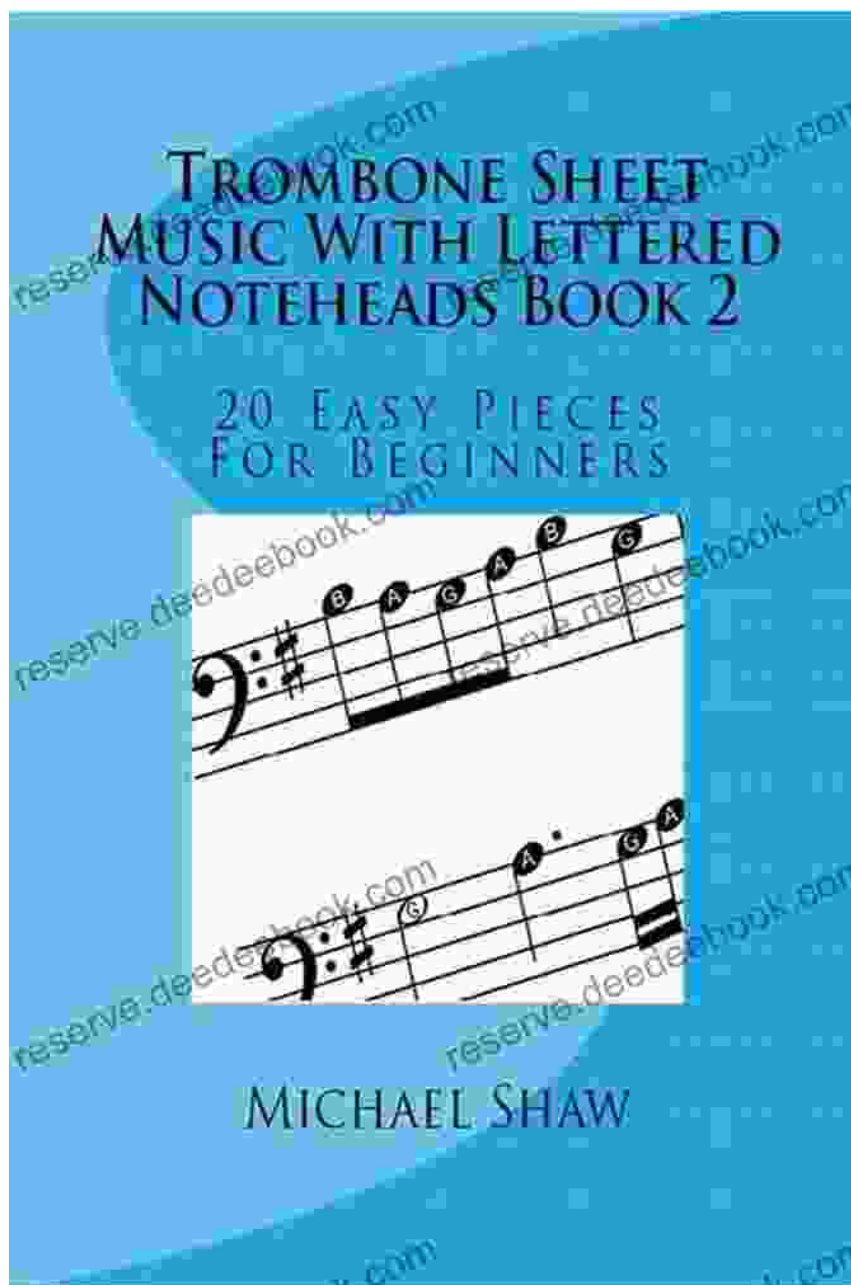

F

E♭ ALTO SAXOPHONE TRILL FINGERING CHART

Move the red key rapidly to produce the trill.
○ = open
● = pressed down

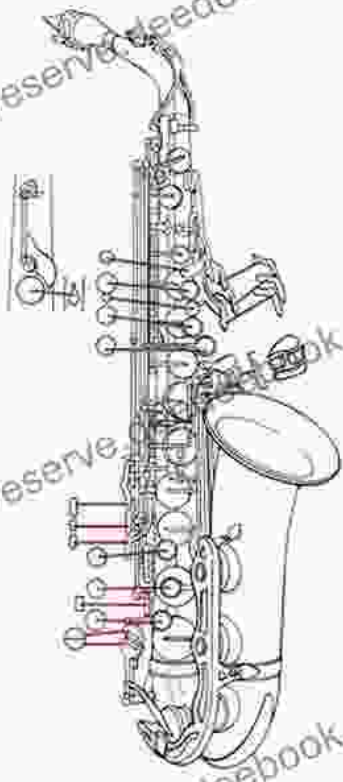

C♭ to D	D to E	E to F	F to G♭	F to G♭			
G♭ to A	A to B♭	A to B♭	A♭ to B	B♭ to C			
B to C	C to D	C to D	C to D	D to E			
E♭ to F	F to G♭	F to G♭	A♭ to B	A♭ to B			
B to C	B to C	C to D	C to D	C to D	D to E	E to F	E to F

G

E♭ ALTO SAXOPHONE TRILL FINGERING CHART

Move the red key rapidly to produce the trill.
 □ = open
 ● = pressed down

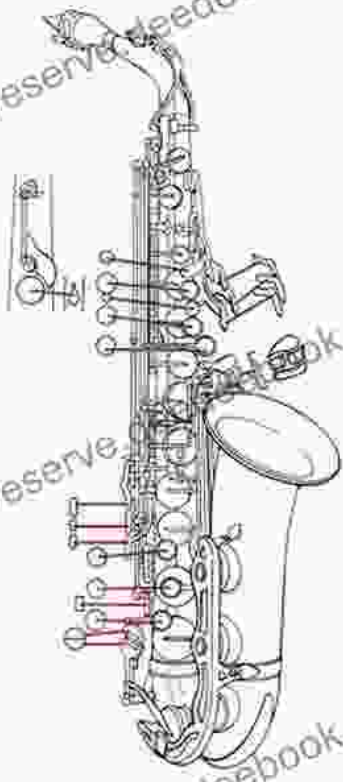

C♭ to D	D♭ to E	E♭ to F	F to G♭
G♭ to A	A to B♭	A♭ to B	B♭ to C
B to C	C to D	C♯ to D♯	D♯ to E
E♭ to F	F to G♭	F♯ to G♯	A♭ to B

B♭ to C B to C C to D♯ C to D C♯ to D♯ D to E E♭ to F E to F



Mastering the Tenor Sax Fingering Chart

Now that you're familiar with the lettered noteheads, it's time to embark on the next chapter: mastering the tenor sax fingering chart. This chart is a roadmap that guides you in placing your fingers on the saxophone keys to produce the correct notes.

To help you visualize the fingering positions, we've included an interactive fingering chart below. Simply click on any notehead to see the corresponding fingering. You can also download a printable version of the fingering chart for your convenience.

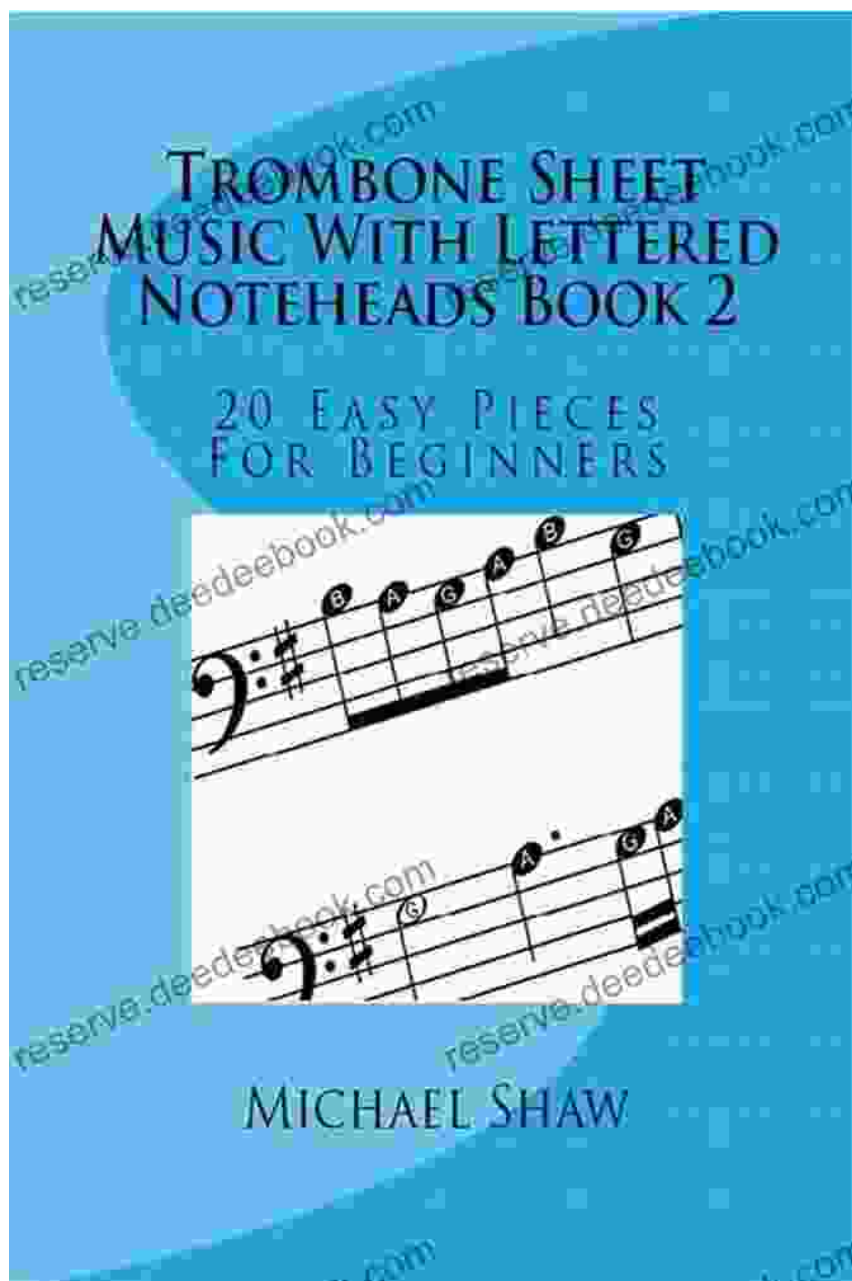

TROMBONE SHEET MUSIC WITH LETTERED NOTEHEADS BOOK 2

20 EASY PIECES
FOR BEGINNERS



MICHAEL SHAW

E♭ ALTO SAXOPHONE TRILL FINGERING CHART

Move the red key rapidly to produce the trill

□ = open

● = pressed down

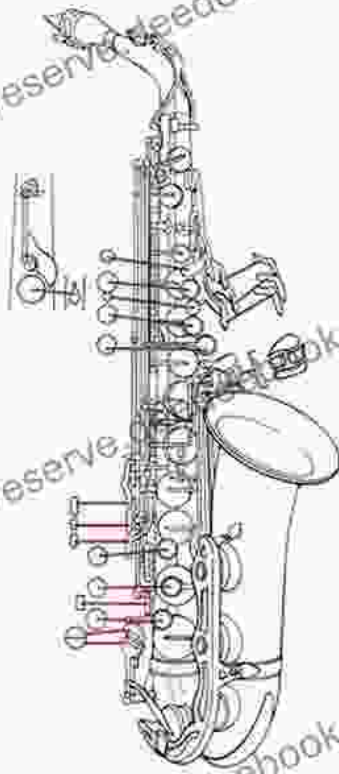

C♯ to D	D♯ to E	E♯ to F	F to G♯	F♯ to G♯

G♯ to A	A♯ to B♯	A to B♯	A♯ to B	B♯ to C

B to C	C to D	C♯ to D	C♯ to D♯	D♯ to E

E♯ to F	F to G♯	F♯ to G♯	A♯ to B♯	A♯ to B

B♭ to C	B to C	C to D	C to D	C♯ to D♯	D to E	E♭ to F	E to F

TROMBONE SHEET MUSIC WITH LETTERED NOTEHEADS BOOK 2

20 EASY PIECES
FOR BEGINNERS



MICHAEL SHAW

TROMBONE SHEET MUSIC WITH LETTERED NOTEHEADS BOOK 2

20 EASY PIECES
FOR BEGINNERS



MICHAEL SHAW

E♭ ALTO SAXOPHONE TRILL FINGERING CHART

Move the red key rapidly to produce the trill

□ = open

● = pressed down

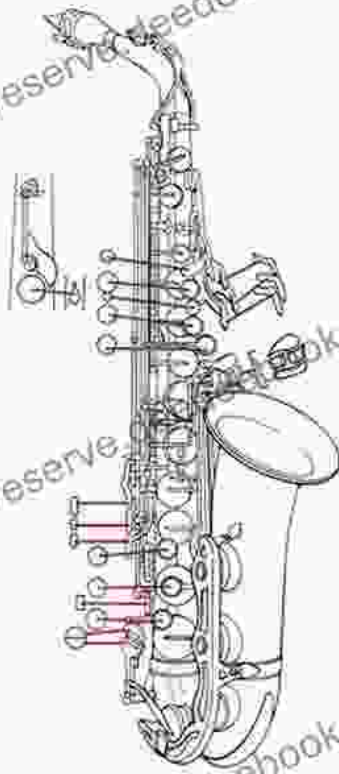

C♯ to D	D♯ to E	E♯ to F	F to G♯	F♯ to G♯

G♯ to A	A♯ to B♯	A to B♯	A♯ to B	B♯ to C

B to C	C to D	C♯ to D	C♯ to D♯	D♯ to E

E♯ to F	F to G♯	F♯ to G♯	A♯ to B♯	A♯ to B

B to C	B to C	C to D	C to D	C♯ to D♯	D to E	E to F	E to F

E♭ ALTO SAXOPHONE TRILL FINGERING CHART

Move the red key rapidly to produce the trill

□ = open

● = pressed down

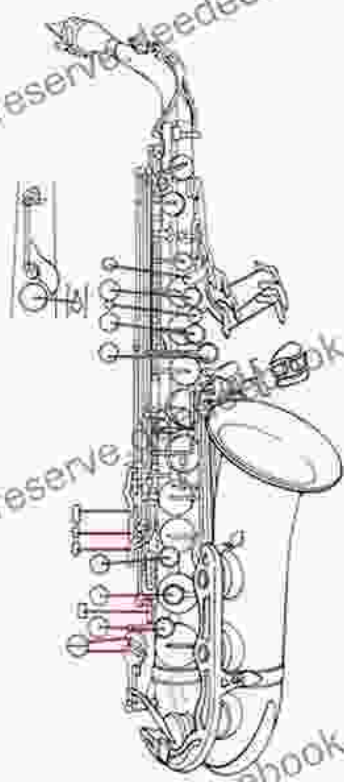

C4 to D4	D4 to E4	E4 to F4	F4 to G4	G4 to A4

A4 to B4	B4 to C5	C5 to D5	D5 to E5	E5 to F5

F5 to G5	G5 to A5	A5 to B5	B5 to C6	C6 to D6

D6 to E6	E6 to F6	F6 to G6	G6 to A6	A6 to B6

B6 to C7	C7 to D7	D7 to E7	E7 to F7	F7 to G7	G7 to A7	A7 to B7	B7 to C8

[Download Printable Fingering Chart: PDF](#)

Practice Exercises for Beginners

Now that you're equipped with the knowledge of lettered noteheads and fingerings, let's put your skills to the test with some beginner-friendly practice exercises.

Exercise 1: Note Identification

Look at the following sheet music excerpt and identify the lettered noteheads. Write the corresponding note names below each notehead.

The image shows the cover of a music book titled "TROMBONE SHEET MUSIC WITH LETTERED NOTEHEADS BOOK 2" by Michael Shaw. The cover is blue with a white rectangular area containing two musical staves. The top staff has six notes with lettered heads: G, A, G, A, B, G. The bottom staff has four notes with lettered heads: G, A, G, A. The book title and author's name are printed on the cover. There is a watermark "reserve.deedeebook.com" repeated across the cover.

Answer:

1. G

2. F
3. E
4. D
5. C
6. B
7. A

Exercise 2: Finger Position Practice

Using the fingering chart, practice playing the following sequence of notes:

- A
- B
- C
- D
- E
- F
- G

Repeat this exercise regularly to improve your finger dexterity and coordination.

Exercise 3: Simple Melody Playing

Now, let's combine your note-reading and finger-playing skills to play a simple melody:

Recorda-Me
Exercise 3: Simple Melodies - Play Less!

Am7
Cm7
F7
Bbm7 Bbm7 Eb7 Abm7 Bbm7 Abm7 Dm7
Gbm7 Gm7 Cm7 Fm7 Eb7
Am7
Cm7 F7
Bbm7 Bbm7 Eb7 Abm7 Abm7 Dm7
Gbm7 Gm7 Cm7 Fm7 Eb7 Am7

© 2008 Music For All

Take your time and practice this melody until you can play it smoothly and confidently.

Additional Tips for Success

- Practice regularly: Consistency is key to mastering tenor sax sheet music. Set aside a dedicated practice time each day.
- Use a metronome: A metronome helps you maintain a steady tempo and improve your rhythm.
- Listen to recordings: Listen to professional tenor sax players to familiarize yourself with the sound and phrasing of the instrument.
- Join a band or ensemble: Playing with others can be a great way to learn and motivate yourself.
- Be patient and persistent: Learning to play the tenor sax takes time and effort. Don't get discouraged, and keep practicing!

Congratulations on embarking on your musical journey with tenor sax sheet music with lettered noteheads! With dedication and practice, you'll unlock the world of saxophone playing and experience the joy of creating beautiful music.

Remember, the path to mastery is paved with consistent effort and a love for music. Embrace the learning process, enjoy the challenges, and let the tenor sax become an extension of your musical expression.

We wish you all the best on your musical endeavors. Happy playing!

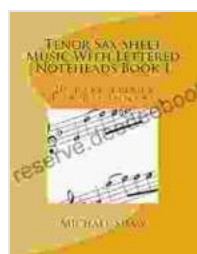

Tenor Sax Sheet Music With Lettered Noteheads Book 1: 20 Easy Pieces For Beginners by Michael Shaw

★★★★☆ 4 out of 5

Language : English
File size : 8804 KB
Text-to-Speech : Enabled
Screen Reader : Supported

Enhanced typesetting : Enabled
Word Wise : Enabled
Print length : 72 pages
Lending : Enabled



An Immersive Exploration into the World of Big Note Sheet Music with Lettered Noteheads: A Revolutionary Tool for Aspiring Musicians

: Embarking on a Musical Odyssey The pursuit of musical excellence is an enriching and fulfilling endeavor, yet the path to mastery can often be shrouded in challenges....

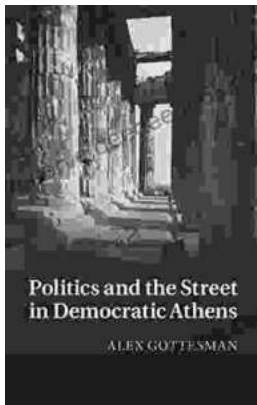

Politics And The Street In Democratic Athens

The streets of democratic Athens were a lively and chaotic place, full of people from all walks of life. The city was home to a large and diverse population,...